



MVAN

VANLIFE GEARS & SOLUTIONS

INDEX

- **DETACHABLE COMPONENTS**
- RACKS AND PLATES**
- CRYSTALS AND PORTALS**
- RETRACTABLE ROOFS**
- LEVELS AND SURFACES**
- ELECTRICAL NETWORKS**
- HEATING**
- PLUMBING NETWORKS**
- ALTERNATIVE INSTALLATIONS**

A wooden detachable MVan module is shown in a dark setting. The module features a raised platform with a light-colored wooden top surface. Below the platform are two drawers with dark handles. A black bag is resting on the platform. The module is designed to be attached to a vehicle.

DETACHABLE COMPONENTS

Engineered for various vehicle types, the detachable MVan modules convert your van into a fully equipped camper van.



Our courses

Engineered for various vehicle types, MVan removable modules convert your van into a complete campervan. Each module provides optimal flexibility while occupying minimal space and eliminating the requirement for vehicle certification.

The modules consist of:

Kitchen area featuring a worktop and designated space for a stove or induction hob. There are also specific storage areas available.

Tables, drop-leaf tables, and work surfaces;

Rapid Access Bed;

Systematic and readily available storage;

Cantilevered extraction guides capable of supporting loads of up to 200 kg.

Each module is crafted and developed to fulfill all customer requirements and will be designed in 3D to provide a detailed visualization of the spaces and environments.



215 €

Stainless steel basin
and tap

2400 €

Culinary Unit

2500 €

Basic Bed Box Unit

1600 €

Refrigerator and Storage
Module



Modulo NEST

Created to convert the van's interior into a cozy sleeping space. It can fit a double bed (200x140 cm) with built-in storage compartments.

The materials are both lightweight and durable, while the design allows for customization. It provides an environment that adjusts to life on the road, without necessitating permanent alterations.

from
2890 €

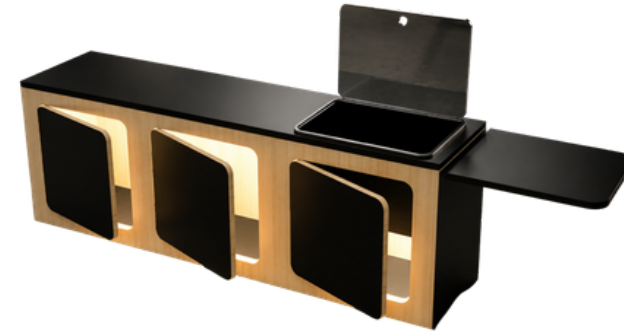

Modulo OASIS

The camp model features a steel sink, tanks, dedicated storage, and a comprehensive water system.

The system is engineered for rapid assembly and disassembly, fully adhering to safety and approval standards, without necessitating structural alterations to the vehicle.

from
2490 €



COOLER Unit

Camp model featuring a refrigerator compartment, a fold-down table, and a double dedicated storage compartment.

The module is securely attached to the original sliding tracks, guaranteeing both stability and reversibility of the configuration.

from
1880 €



Modulo DOUBLE SYSTEM

The DOUBLE SYSTEM is entirely detachable in three segments. This module design enables cooking both inside and outside the vehicle by adjusting the slides.

The two modules are linked by a pre-drilled board that allows the mattress to breathe, forming a bed that is level with the folded seat.

from
4490 €



Modulo VOYAGER

Pro model, featuring the NEST, OASIS, and COOLER modules.

The VOYAGER module is a completely detachable monoblock equipped with 200 kg slides. It includes electric movement and is prepared for connection to the vehicle, providing both convenience and practicality.

from
6260 €



Modulo HOVEN

Hoven Module. Cozy, detachable, and exceptionally resilient.

The HOVEN module is designed to be very low, specifically for California Beach vans. It includes a pull-out kitchen and a drawer refrigerator, optimizing the space beneath the trunk.

from
2490 €



Modulo FREEDOM

The Liberty is a five-block configuration tailored to meet every requirement.

The module consists of two rear lockers that convert into a bed, two front seats combined with a pull-out table made of durable wood, a kitchen module, and a shower equipped with a 12-volt electric boiler for the outdoor shower.

from
7890 €

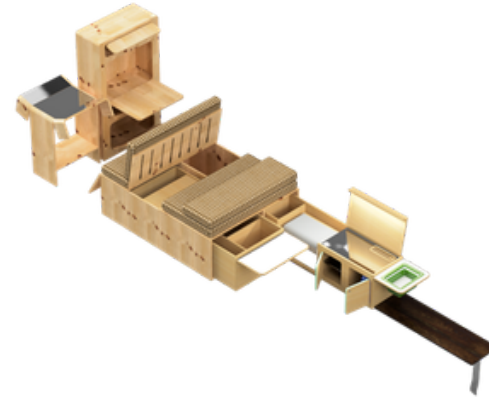

Modulo FULL CUSTOM

The Full Custom module is a singular unit specifically created for Ford Custom vehicles.

Completely detachable, featuring a bed that transforms into a seat, a retractable kitchen, and room for a refrigerator. The module comprises a standalone water system, a shower, a fold-out table, storage solutions, and a wardrobe that can be converted into a work surface.

from
9980 €



ERASMUS Application Form

A cargo module featuring an accordion bed, a retractable mini kitchen, and compact storage, designed for rapid setups in vehicles with restricted space.

The Erasmus module offers an excellent option for individuals seeking convenient solutions and rapid installations through a plug-and-play approach.

from
4990 €



Accordion bed unit

The module serves as a compact solution intended to convert the rear compartment into a practical sleeping space.

Thanks to its foldable design, it maximizes space, providing enhanced freedom for loading and movement within the van. It is perfect for individuals seeking a straightforward, lightweight, and functional arrangement.

from
1290 €



Modulo MOTORBIKE

The MOTORBIKE module is intended for athletes requiring the transportation of motorcycles or bicycles.

The module features a foldable bed that rests against the wall, with the possibility of incorporating a pull-out kitchen on the side, positioned above a rear wheel cover.

from
4890 €



SPC laminate flooring

Engineered to establish a robust, practical foundation within the vehicle, enhancing the functionality of the area.

The design conforms to the contours of the compartment, allowing for seamless integration with detachable modules. This presents an excellent option for individuals looking to safeguard the underbody and ready the van for upcoming modifications.

from
1290 €



Stainless steel basin

Stainless steel sink measuring 325x265x150 mm, featuring a 90° angled waste, a 19 mm hose connection, a steel plug, and an integrated tap.

Suitable for all types of vehicles

214,82 €



Hob

Induction hob 1800, HENDI, Kitchen Line, 230V/1800W, 319x355x(H)67mm. Digital power, temperature, and timer settings. Maximum capacity: 15 kg.

Appropriate for pots ranging from 120 to 260 mm in diameter.

182,39 €



Vitrifrigo VF16P

The VF16P portable refrigerator-freezer is engineered to provide you with the convenience of transporting fresh food and beverages wherever you travel.

Featuring a compact and lightweight design, weighing just 8 kg, it offers a total capacity of 16 litres, organized into 2 compartments, indicating a thoughtful separation of the items within.

761,14 €



10-liter canister

10-liter tank for the water systems of your removable module.

The container features a sizable resealable opening with a screw-on lid and allows for complete internal inspection.

27,33 €



Submersible pump

A streamlined and effective approach for water management in low voltage systems.

Due to its sleek design, featuring a diameter of merely 38 mm and a height of 104 mm, it can effortlessly fit into even the most confined tanks or canisters.

24 €



ONTAP outdoor shower system

Transform each stop into a moment of complete relaxation. Featuring a 22-liter polyethylene tank, an integrated 12V pump, and a 7-jet multifunction nozzle, it represents the ultimate solution for individuals in pursuit of comfort and cleanliness.

Lightweight, durable, and prepared for immediate use.

399 €

The image shows the rear of a dark-colored camper van with its cargo door open. The interior of the door is lined with a complex, modular metal transport system. This system consists of several vertical racks and horizontal plates, all featuring a perforated design for weight reduction and ventilation. The racks are labeled 'DSRT'. The plates are arranged in a way that allows for the secure transport of various items. The background shows a bright, indoor setting, possibly a showroom or a workshop, with a blue sign that reads 'twinbusch.de' visible on the left.

RACKS AND PLATES

The core of the DSRT line is the modular rear transport system, engineered to accommodate all loading requirements. The diverse options provided enable you to customize the rear of your camper with highly durable plates.



Installation of rack and brackets

MVan Solutions serves as an authorized dealer and installer of Kreavans products, a prominent European brand known for its durable, modular camper accessories featuring a distinctive design.

Through the DSRT by Kreavans line, we provide solutions tailored for true travelers: vanlifers, overlanders, and campers who prioritize reliability, flexibility, and premium quality without compromise.

Each DSRT product is crafted to be practical, long-lasting, and adaptable, and can be acquired individually or installed directly through MVan Solutions.

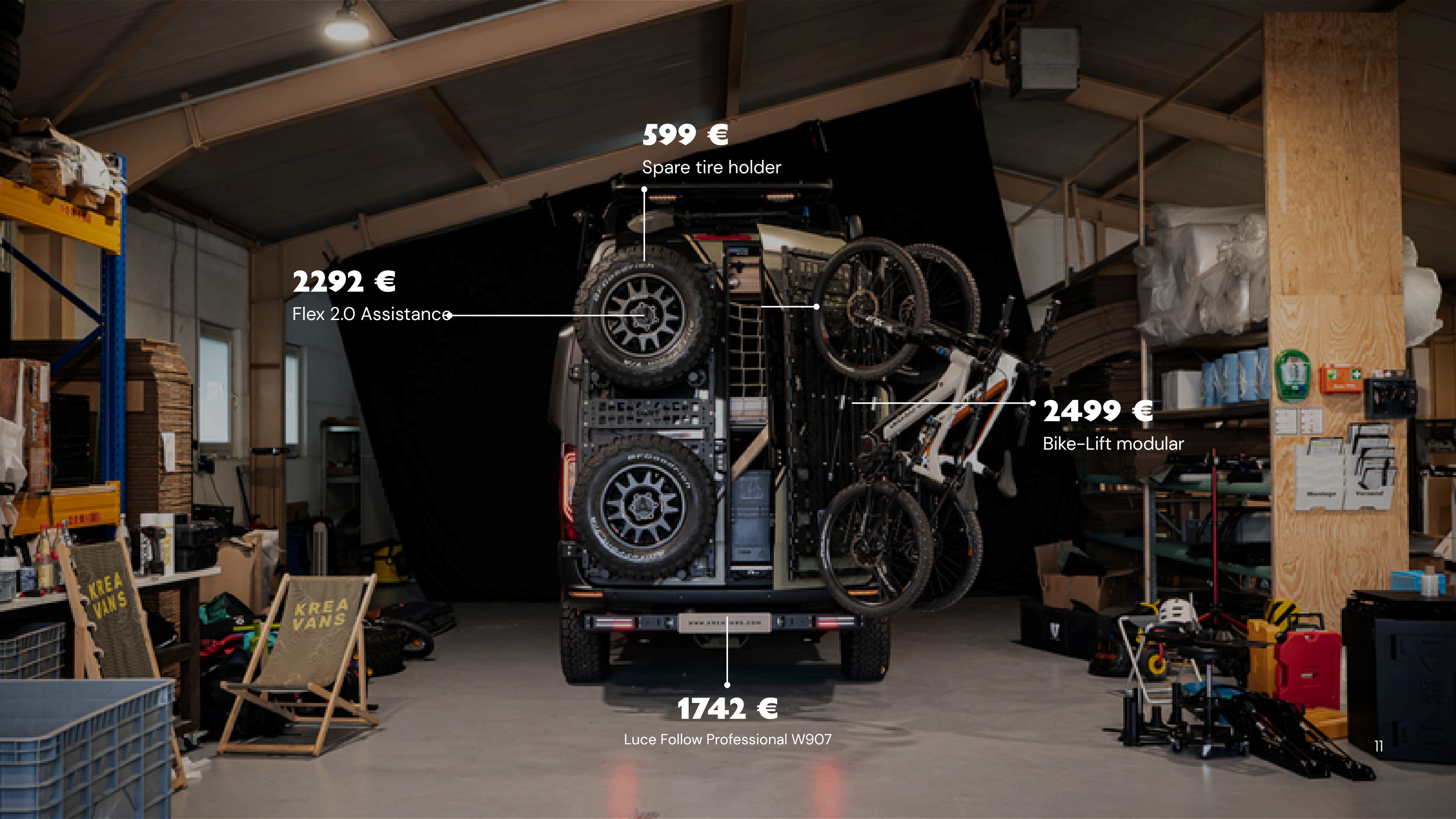

599 €

Spare tire holder

2292 €

Flex 2.0 Assistance

2499 €

Bike-Lift modular

1742 €

Luce Follow Professional W907

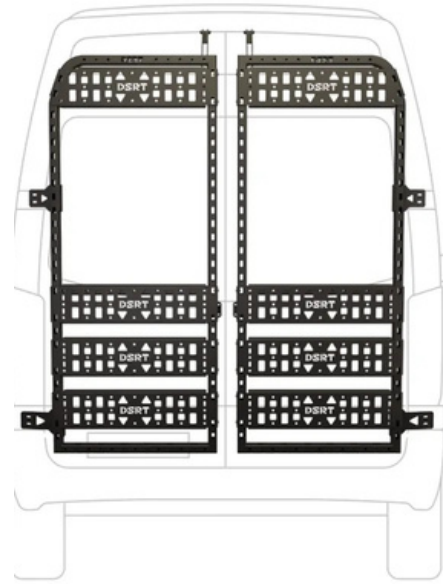

Supperto Flex 2.0

Modular and adaptable – as customizable as your configuration. Constructed from 4mm extruded aluminum, it provides outstanding strength and stability.

KTL and powder coating provide lasting durability. They are easy to install and remove, and due to compatible adapter plates, they can be reused even when switching vehicles.

2292,86 €



Bicycle rack + Container

The Bike-Rack 2er integrates bike transportation and storage into one solution. Bikes are positioned transversely on a compact, S-sized box, making it perfect for both road and mountain bikes.

An optimal solution for individuals seeking to merge flexibility, security, and storage capacity within one system.

2199 €



Box DSRT

It merges strength and versatility, making it perfect for individuals looking for protection and practicality in a compact form. Constructed entirely from premium aluminum and coated with a resilient powder finish.

This box is crafted for durability and to uphold a professional appearance, even with frequent use.

1349 €



Spare tire holder

The spare wheel carrier, with a weight of 3.5 kg, is individually adjustable to accommodate nearly any wheel size. The central screw fastening guarantees a secure and stable connection to the vehicle.

Secures your spare wheel firmly in place and ensures it is always readily accessible, even during challenging trips.

599 €



Base support plates

Compact and straightforward, constructed from premium aluminum, they provide an ideal base for modular systems. Highly resilient.

The integrated system facilitates a flexible and straightforward installation of all modules. Despite its lightweight construction, it accommodates up to 70 kg, preparing your van for any adventure.

1299 €



Ski storage rack

Ski rack designed for the secure transportation of skis and snowboards. With locking mechanisms at both the top and bottom, it can accommodate up to three pairs of skis.

Constructed from powder-coated aluminum, the ski rack is built for durability, providing both convenience and safety on every journey to the snow.

849 €



Engine safeguarding

Engineered exclusively for the Mercedes Sprinter equipped with four- or six-cylinder engines, it provides superior protection during off-road activities. It safeguards the engine against impacts and debris.

Robust, thoughtfully crafted, and essential, it serves as the ideal companion for the most challenging off-road excursions.

1599 €



Transmission safeguarding

The Transmission Guard 4 Cyl serves as an ideal addition to the engine guard, providing dependable protection for the gearbox against impacts and damage during off-road activities.

Robust and engineered for rigorous off-road applications, it guarantees safety and longevity even in the most challenging environments.

499 €



Side panel for the box

For attaching equipment to the side of the Box.

This accessory is perfect for individuals looking for both protection and practicality in a compact form. It is constructed entirely from high-quality aluminum and features a robust powder-coated finish.

170 €



Differential protection system

The vehicle's lowest point is thoroughly safeguarded. The Differential Guard for the MB Sprinter is constructed from robust, powder-coated aluminum, providing protection for the differential against impacts and damage during off-road activities.

It can be coated in any hue, providing fashionable protection while maintaining functionality.

529 €

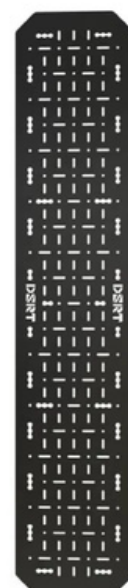

Side-Rack

The Side-Rack enhances the storage capacity on the side of the vehicle, making it perfect for adventurers requiring additional space. It is especially suitable for equipment that is not used on a regular basis.

Its raised location safeguards your equipment from dirt and theft.

2599 €



Surf-Rack

Fitted with a universal stand featuring specialized inserts that securely hold the board in place during transportation.

Foil boards can be transported without removing the mast, which saves considerable time and provides greater freedom to enjoy the ride.

1399 €



ELECTRICAL SYSTEM

At MVan Solutions, we develop tailored electrical systems, crafted following an extensive initial analysis, allowing us to suggest the solutions that best align with your travel preferences and power requirements.



Energy and comfort throughout every journey

Convert your van into a genuine sanctuary on wheels, prepared to join you on every journey.

RV electrical systems play a crucial role in supplying power to devices and systems that enhance comfort, safety, and functionality while on board.

At MVan Solutions, we develop tailored electrical systems, crafted following an extensive initial analysis, allowing us to suggest the electrical solutions most appropriate for your travel preferences and range requirements.



158 €

Control panel NE333

228 €

Polycrystalline Solar Module

28 €

Slim recessed LED strip

730 €

Battery service



Spot Flexible 3200k

The LED spotlight boasts a practical and elegant design, equipped with a flexible neck and a sleek black finish, allowing for easy positioning in any location. It delivers a warm, focused output of 105 lumens.

Featuring a power consumption of 2W, it includes a built-in USB port for charging smartphones, tablets, or other USB-compatible rechargeable devices.

32 €



Adjustable Spotlight 4000k

A flexible lamp featuring a practical and elegant design, equipped with a flexible neck and a black finish, enabling it to be positioned as required.

It produces a vivid and focused light of 90lm, featuring a neutral white hue.

59,17 €



Adjustable LED floodlight

This recessed spotlight is designed with an opal glass lens and a brushed aluminum frame, offering a contemporary and sophisticated appearance.

With a diameter of 68 mm, it is suitable for a 52 mm hole and produces a warm white light at 3200K. Intended for indoor applications.

34,65 €



2000W Pure Sine Wave Inverter

2000W Pure Sine Wave Inverter designed to convert direct current into alternating current, optimizing the efficiency of your photovoltaic panel.

With a continuous output of 2000W and a peak of 4000W, it is suitable for use with lithium batteries.

559,98 €



Power Plant + Lithium Ion Battery

Energy solution tailored to fit beneath the driver or passenger seat.

Featuring a 100Ah LiFePO₄ battery, a 25A DC-DC converter, and a 25A MPPT regulator (32V, 290W), it enables charging through an alternator, AC outlet, or solar power.

1688,48 €



Power Service PLUS 25 Amperes

A genuine travel charger, designed to recharge service batteries more quickly than the alternator by itself.

The Plus and Gold versions include a charge regulator for controlling solar panels and a 230V mains charger. This device ensures a complete charge in half the time compared to an alternator.

586,56 €



Presca Scanstrut USB-A+C + 12V

The Flip Pro Duo SC-MULTI-F2 is a high-performance multi-power outlet, specifically engineered to endure the challenges of the nautical environment.

Integrates a high-power USB-A / USB-C charger and a 12V socket into a single, compact, and robust module, ideal for ensuring devices remain charged while on the move.

62 €



Scanstrut Waterproof USB-A Port

The SC-USB-01 USB socket is engineered to charge electronic devices under any weather conditions, specifically designed and developed to endure atmospheric elements in the maritime sector.

The UV-resistant container and stainless steel components provide resistance to water and rain, guaranteeing safety and reliability in outdoor settings.

37,50 €



Portable Power Station VoltaB

A portable electric power station engineered to provide dependable power wherever needed.

Perfect for vans, outdoor activities, events, and electric mobility, VOLTAB merges power, quiet operation, and sustainability into one device. It serves as a genuine alternative to conventional generators.

3099 €



AC-DC 60A Battery Charger

The BC60WBPRO is a smart charger engineered to charge 12V batteries efficiently, safely, and rapidly.

With a maximum charging current of 60A, it ensures optimal performance across various applications, including cars, boats, campers, and energy storage systems.

252 €



Third Traffic Signal

The third brake light features LED lights and chrome trim. This waterproof light bar is designed to withstand various weather conditions and is resistant to the intrusion and corrosion caused by sand, dust, dirt, water, snow, and other elements.

Can be incorporated into any vehicle and ensures optimal braking safety.

59,58 €

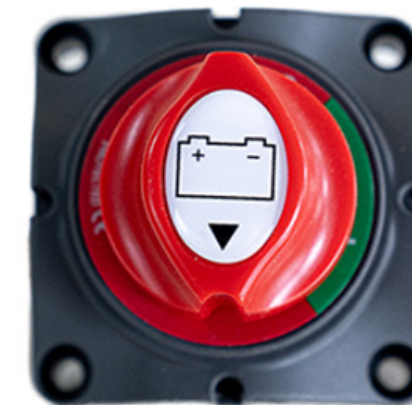

Mini Size Current 50 Amperes

The battery switch enables you to disconnect the power supply to the vehicle or the onboard battery.

Constructed from tinned copper and ABS plastic, the tin plating enhances the antioxidant and discoloration characteristics of red copper, prolonging its rust resistance without compromising conductivity.

27,36 €



Koven LiFePO4 100Ah

Engineered for installation beneath the seat, this LiFePO4 battery merges energy density with the safety features of Lithium-Iron-Phosphate technology.

Featuring more than 4,000 life cycles, integrated Bluetooth connectivity for monitoring, and a 5-year warranty, it stands as the premium option for individuals who refuse to settle.

451,40 €



Koven LiFePO4 180Ah

This battery exemplifies technological superiority in the realm of vanlife. With its durable ABS casing and optimized size, it is specifically engineered for installation beneath the seat.

Featuring more than 4,000 life cycles, integrated Bluetooth for monitoring, and a 5-year warranty, it stands as the top option for individuals who refuse to settle.

730,78 €



Koven LiFePO4 270Ah

Thanks to its metal casing and optimized dimensions, the natteria is designed to fit perfectly under the seat of your van.

Featuring more than 4,000 life cycles, integrated Bluetooth for monitoring, and a 5-year warranty, it stands as the top option for individuals who refuse to settle.

962,58 €



Koven LiFePO4 300Ah

Forget the heavy weight and limited lifespan of conventional batteries. This LiFePO4 battery exemplifies technological advancement for the vanlife community.

Constructed from reinforced ABS and featuring optimized dimensions, it is intended to fit seamlessly beneath the seats of the leading vans and campers available in the market.

925,98 €



Koven LiFePO4 330Ah

With 330Ah of pure LiFePO4 technology, this battery serves as the essential core of intricate electrical systems.

Created for dedicated travelers, it provides more than 4,000 charging cycles and features integrated Bluetooth monitoring, with a weight of only 27kg. The top-tier solution for ensuring you never have to compromise on your onboard appliances.

973,56 €



Koven LiFePO4 700Ah

Engineered for installation beneath the seat, this 12.8V LiFePO4 battery merges energy density with the safety features of Lithium-Iron-Phosphate technology.

With more than 4,000 life cycles, integrated Bluetooth connectivity for real-time monitoring, and a 5-year warranty, it stands as the premium option for individuals who refuse to compromise while on the road.

2438,78 €

A dark-colored van is shown from a front-quarter perspective, parked in a desert landscape. The van's headlights are on, and it has a heavy-duty front bumper with auxiliary lights. The background shows a vast, arid desert under a clear sky.

HEATING

Dependable, secure, and efficient heating systems, crafted to provide thermal comfort throughout the year. Experience complete comfort in your van even during the coldest months, without the need to keep the engine running.



The solutions selected by MVan

Traveling in a campervan is not solely a summer enjoyment. With a permanent heating system, you can experience complete comfort in your van even during the coldest months, without the need to keep the engine running.

At MVan Solutions, we create and implement dependable, secure, and high-efficiency heating systems, crafted to provide thermal comfort throughout the entire year.

This is the reason we exclusively utilize Autoterm products.



756 €
Autoterm Air 2D

891 €
Autotherm Air 4D
System



Autoterm 2D Heater

The Autoterm Air 2D stands as the most compact diesel air heater available in the lineup. Featuring a heating output of 2 kW, it is perfectly suited for small vehicles.

The Autoterm 2D heater produces up to 75 m³ of warm air each hour while utilizing a maximum of only 0.24 liters of diesel fuel. Its energy consumption reaches a maximum of 29 W/h.

756,40 €



Autoterm 4D Heating System

Autoterm Air 4D heater featuring a heating capacity of 4KW for air heating. The heating power is adjustable manually in performance mode. The Autoterm Air 4D possesses an ECE test mark, allowing for installation without the requirement of registration.

891,81 €



Autoterm 9D Heater

The most powerful heater in the Air series, designed for heating expansive areas or interiors. Perfect for all types of vehicles, ranging from camper compartments to boat interiors.

Dependable performance is maintained even in low temperatures, down to -45 °C, with a diesel consumption ranging from 0.42 to 1.00 litres per hour.

1738,58 €



Combi Boiler 7L Autoterm

A compact, advanced hot water boiler featuring three flexible heating options. The Combi Boiler heats water from 20 to 60°C in about 60 minutes.

Monitored and managed through the Autoterm Boiler Control control panel.

1178,75 €



Stainless steel container suitable for inspection

A stainless steel container is beneficial for the installation of diesel heaters on the exterior of a camper or van, helping to conserve space.

The enclosure safeguards the heater from external elements.

Offered in two versions:
per Autoterm 2D
per Autoterm 4D

183,29 €



Panel Comfort Control Autoterm

The Comfort Control panel serves as your perfect companion for operating the Autoterm air heater in your camper or van.

With its user-friendly interface and a variety of features, you can tailor the comfort of your vehicle throughout the year.

197,93 €



CRYSTALS AND PORTALS

At MVan Solutions, we specialize in the installation of windows, skylights, and ventilation systems that enhance vehicle habitability by facilitating air exchange, providing insulation, and offering protection.



The line suggested by MVan

Effective management of natural light and ventilation is crucial for ensuring a comfortable living experience in the van throughout all seasons.

At MVan Solutions, we specialize in the installation of windows, skylights, and ventilation systems that enhance vehicle habitability by facilitating air exchange, providing insulation, and offering protection.

Each project is customized according to the van model, its purpose, and travel requirements, incorporating functionality, design, and construction quality.



285 €

Oblock Thule Omnivent

230 €

45×45 compass window



30×45 compass window

The MASIS van window is crafted with the utmost quality, providing a dependable and long-lasting solution for your vehicle.

Thanks to its hinged opening, it provides enhanced visibility and ventilation for your van. The sophisticated dark black design complements any decor style seamlessly.

204,42 €



45×45 compass window

The MASIS van window is crafted with the utmost quality, providing a dependable and long-lasting solution for your vehicle.

Thanks to its hinged opening, it provides enhanced visibility and ventilation for your van. The sophisticated dark black design complements any decor style seamlessly.

230,58 €



85×45 compass window

The MASIS van window is crafted with the utmost quality, providing a dependable and long-lasting solution for your vehicle.

Thanks to its hinged opening, it provides enhanced visibility and ventilation for your van. The sophisticated dark black design complements any decor style seamlessly.

248,67 €



Blackout curtain and mosquito net 30×45

Internal cassette fully equipped with blinds and mosquito netting made of white aluminum. Standalone components featuring automatic retraction.

You have the option to use either the blackout blind or the mosquito net, or both, at varying heights, allowing for the possibility of connecting them with a magnet.

124,64 €



Blackout and mosquito net 45×45

Internal cassette fully equipped with blinds and mosquito netting made of white aluminum. Standalone components featuring automatic retraction.

You have the option to use either the blackout blind or the mosquito net, or both, at varying heights, allowing for the possibility of connecting them with a magnet.

148,22 €



Blackout curtain and mosquito net 85×45

Internal cassette fully equipped with blinds and mosquito netting made of white aluminum. Standalone components featuring automatic retraction.

You have the option to use either the blackout blind or the mosquito net, or both, at varying heights, allowing for the possibility of connecting them with a magnet.

175,53 €



Turbo Vent White 40 x 40

Traditional porthole featuring a 12 Vdc motor controlled by a speed variator.

The low-profile design of the outer cover enhances the porthole's aerodynamics and ensures quiet operation during travel.

433 €



Purchased Mini Crochet 40x40

Aerodynamically designed glass porthole constructed from durable PMMA, featuring openings on all sides. Easy porthole adjustment through control handles.

Optimal light emission. Featuring a single pleated blackout. Pleated mosquito net in black, with a cream white frame. Continuously adjustable blackout and mosquito net.

255,53 €



Oblo' Midi Heki Design

Rooflight with lever and forced ventilation, grey, 70x50. This enhanced version of the Midi Heki Style rooflight includes upgraded safety, aerodynamics, and maintenance features.

Equipped with reliable features like a blackout blind and mosquito net, along with easier cleaning, it ensures comfort and practicality throughout the journey.

870,46 €



165 mm porthole equipped with a fan

Roof vent featuring a stainless steel mechanism constructed from weather-resistant plastic material.

92,96 €



Oblock Thule Omnivent

The Thule Omnivent 40x40 roof vent serves as the perfect solution for maintaining continuous ventilation and providing instant fresh air within campers and caravans.

Constructed with robust materials and a streamlined design, it guarantees comfort, dependability, and straightforward installation.

285 €



Fiamma Vent Porthole 40 x 40

High-performance portholes. The Fiamma collection of portholes provides exceptional quality and a streamlined lid design that enhances aerodynamics and reduces noise.

Approved, it is constructed from high-quality, shock-resistant, and UV-stabilized materials. It comes with a mosquito net.

171,53 €



RETRACTABLE ROOFS

A pop-top roof allows for the addition of a comfortable sleeping area, enhancing the internal layout of the vehicle while maintaining its original structure.



Increased space, enhanced comfort, and greater freedom

A pop-top roof allows for the addition of a comfortable sleeping area, enhancing the internal layout of the vehicle while maintaining its original structure.

The pop-up roofs we install provide access to the sleeping area through an internal lift porthole, preserving the habitability of the main compartment while offering a practical, discreet, and efficient solution for life on the road.

Installation also on H1



• **8450 €**

Atek retractable roof

1170 €

Flares enlarger



SkyUp Fiat, Peugeot, Citroën

Sky Up® pop-up roofs are entirely manufactured in Italy, crafted to provide lightness, comfort, and optimal reliability in all usage conditions.

Sky Ups are considered some of the lightest options available due to their fiberglass roof. The double-acting lifting mechanism provides a smooth and comfortable experience during both opening and closing, enhancing overall stability.

4990 €



Mercedes SkyUp Rooftop

Sky Up® pop-up roofs are entirely manufactured in Italy, crafted to provide lightness, comfort, and optimal reliability in all usage conditions.

Sky Ups are considered some of the lightest options available due to their fiberglass roof. The double-acting lifting mechanism provides a smooth and comfortable experience during both opening and closing, enhancing overall stability.

4990 €



Talamonti Sky Loft Rooftop

The Sky Loft roof represents a unique solution for H2 vehicles, being the sole roof available in the market that features a manual front opening, enabling the dome to be completely elevated.

Thanks to this groundbreaking system, it is now feasible to create a genuinely livable environment, featuring a consistent internal height of around 85 cm.

5100 €



Iveco Atek rooftop

Atek Van Roof® is a product from Spain tailored for the primary van models. With MVan's expertise, every roof is installed with the highest level of accuracy.

Each project is tailored specifically for the vehicle, guaranteeing seamless integration with the roof, structural integrity, reliability, and long-term durability.

7180 €



Tettuccio Atek Mercedes-Benz

Atek Van Roof® is a product from Spain tailored for the primary van models. With MVan's expertise, every roof is installed with the highest level of accuracy.

Each project is tailored specifically for the vehicle, guaranteeing seamless integration with the roof, structural integrity, reliability, and long-term durability.

8450 €



Atek Volkswagen rooftop

Atek Van Roof® is a product from Spain tailored for the primary van models. With MVan's expertise, every roof is installed with the highest level of accuracy.

Each project is tailored specifically for the vehicle, guaranteeing seamless integration with the roof, structural integrity, reliability, and long-term durability.

7180 €

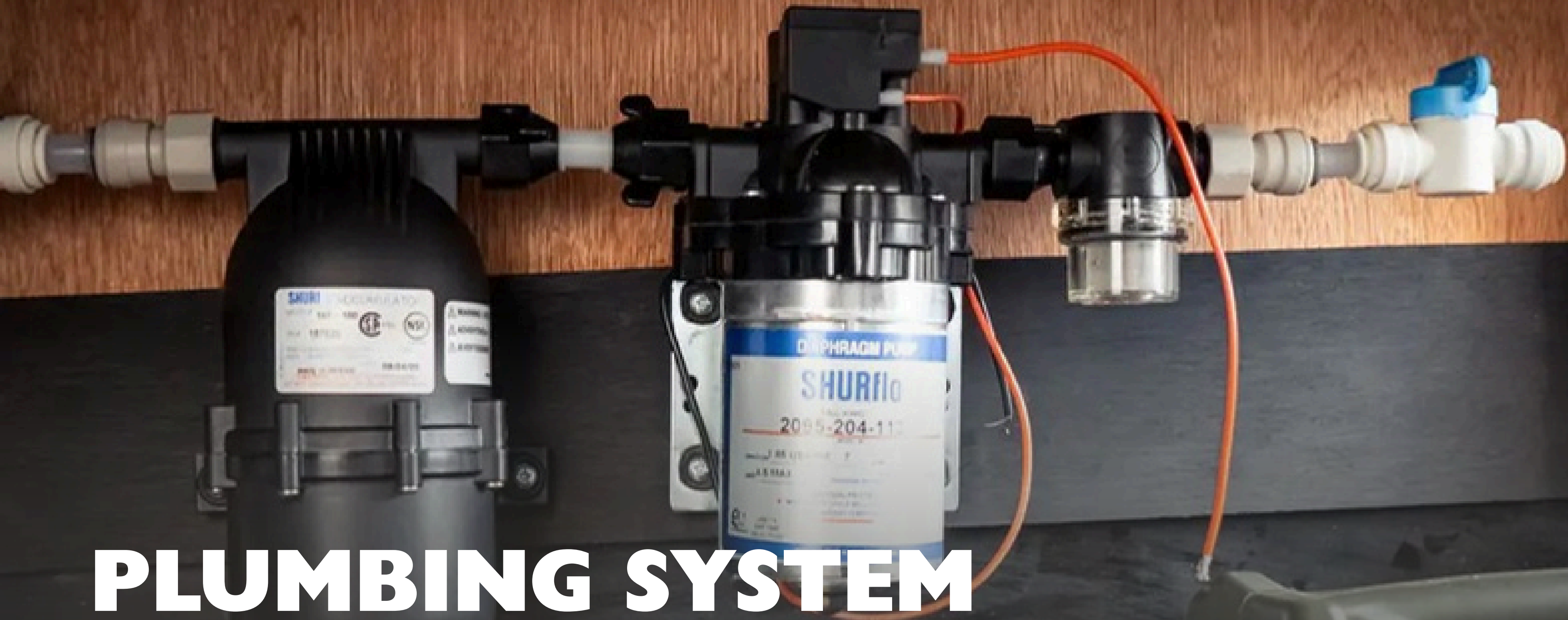

PLUMBING SYSTEM

Bespoke systems for campers and vans, crafted to guarantee optimal comfort on every journey. Each setup is customized to meet the client's requirements and vehicle specifications.



Functionality and autonomy, wherever you travel

At MVan Solutions, we create and construct tailored water systems for campers and vans, aimed at providing optimal comfort on every journey.

Each installation is customized to meet the customer's requirements and the specific configuration of the vehicle, enhancing space, performance, and user-friendliness.

Whether you seek a basic outdoor shower or a comprehensive bathroom system, our solutions are crafted to provide you with hygiene, functionality, and independence, no matter where you are.

214 €

Stainless steel sink with faucet

139 €

60-liter water tank



Pentair Shurflo Pump

Pentair Shurflo Series 4009 Revolution 12V 7.6 L 20 PSI Certified KTW / E-Mark.

A drinking water pump that, due to its single diaphragm and internal bypass, guarantees optimal durability and efficiency for all sanitary piping systems.

192,78 €



CAN with lid sink

Canister with lid that ensures design and style for your kitchen.

Stainless steel base featuring a Scotch-Brite finish, 39 mm drain hole, compact dimensions, and an exceptionally lightweight design.

211,67 €



London faucet

The cold water faucet is a plastic fixture perfect for vans and campers.

Fitted with a tilting spout and microswitch, it is suitable for installation on surfaces up to 25 mm thick and includes a standard fitting.

41,83 €



Twister Blender

Single-lever mixer tap TWISTER E - POLISHED CHROME REICH, designed in a modern and compact plastic, is ideal for the kitchen, shower, and bathroom.

125,76 €



Stainless steel sink with faucet

Stainless steel sink measuring 325x265x150 mm, featuring a 90° angled waste, a 19 mm hose connection, a steel plug, and an integrated tap.

Suitable for all types of vehicles.

214,82 €



12V submerged pump

The submersible pump is a compact pump designed for RV and recreational vehicle uses. It delivers high performance, making it suitable even during travel.

Engineered to deliver up to 30 minutes of uninterrupted operation, it can be powered by a 12V battery, an appropriate power unit, or solar systems.

14,10 €

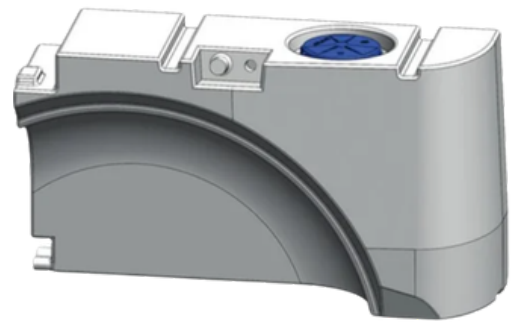

65Lt wheel arch reservoir

65 l drinking water tank

The design of the tank is perfect for installation above the wheel arch within the vehicle.

248 €

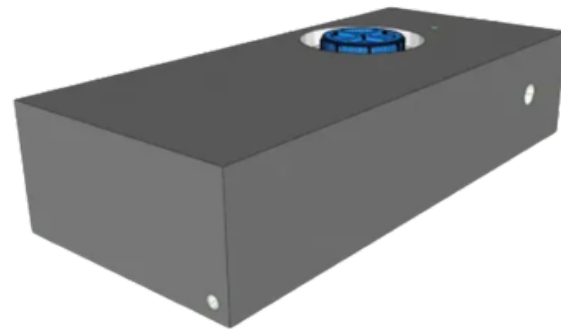

70 L Black Tank

70 Lt black tank 90x40x20cm featuring a green female cap.

156,38 €



10-liter tank

10-liter tank for the water systems of your removable module.

The container features a sizable resealable opening with a screw-on lid and allows for complete internal inspection.

27,33 €

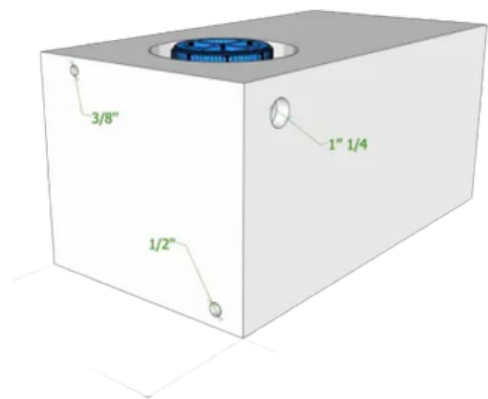

95 L White Tank

The 95-liter tank serves as the perfect solution for campers and vans that need a dependable and secure water supply.

Constructed from natural white non-toxic polyethylene, it ensures durability, impact resistance, and ease of cleaning.

166,94 €



65 Lt Black Reservoir

65 Lt black tank 99x50x14cm featuring a green male cap.

157,26 €

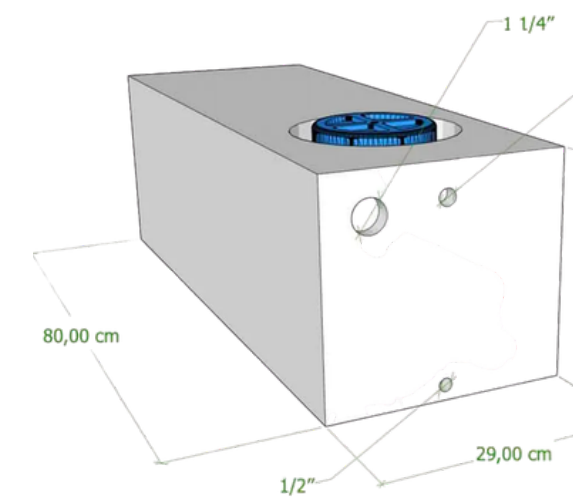

60 L White Tank

60 Lt white tank. Dimensions 80x29x27 cm with a blue female cap.

139,10 €

The image shows the interior of a motorhome. A large, light-colored wooden cabinet is the central focus. To the right, a silver ladder is mounted on the wall. The interior has white walls and dark ceiling panels. There are windows on both sides, and some patterned fabric is visible in the foreground.

LEVELS AND SURFACES

Floors and coverings crafted to merge aesthetics, comfort, and body protection. At MVan Solutions, each surface is designed to endure everyday use.



Solutions tailored to your requirements

Transform your vehicle into a genuine home on wheels, with flooring and coverings crafted to blend aesthetics, comfort, and protection for the body.

Every surface is crafted to endure daily use, guaranteeing durability, practicality, and a design that complements your travel style.

With the help of advanced and effective thermal and acoustic insulation systems, your van transforms into a comfortable environment year-round: cool during the summer, warm in the winter, and quiet both while driving and when parked.



49 €

ABM Butyl Insulation

36 €

Click SPC Flooring

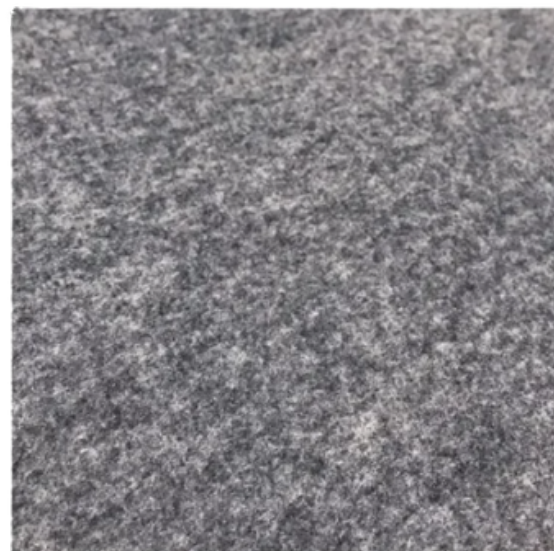

Needle-Punched Flooring

A medium-strength needled textile flooring designed for campers and vans. Composed of 100% polypropylene, with a weight of 1,100 g/m². The backing is treated with latex.

23,79 €



Click SPC flooring

4cm click SPC is perfect for all indoor settings (including bathrooms, kitchens, or wet areas) suitable for both residential and commercial applications.

Constructed from sharp-edged SPC featuring a brushed finish.

36,48 €



ABM Butyl Insulation

The ABM butyl aluminum insulation mat serves as a specialized solution for sound absorption and vibration dampening within the automotive industry.

Perfect for automotive, residential, and construction uses, it offers efficient noise, resonance, and vibration mitigation.

49 €



Armaflex ACE Plus 19 mm | 5 m².

ArmaFlex ACE Plus, produced by Armacell, is an insulation material made of closed-cell elastomeric foam.

It serves as an effective barrier against condensation due to its high resistance to water vapor diffusion. Its thermal conductivity minimizes energy losses in systems and equipment.

199 €



Armaflex ACE Plus 6 mm | 10 m².

ArmaFlex ACE Plus, produced by Armacell, is an insulation material made of closed-cell elastomeric foam.

It serves as an effective barrier against condensation due to its high resistance to water vapor diffusion. Its thermal conductivity minimizes energy losses in systems and equipment.

249 €



Maritime Platform

Interior flooring influenced by the nautical theme, crafted to provide the van with an elegant, warm, and sophisticated appearance.

The longitudinal slats improve the space, enhance the sense of depth, and create a more organized and sophisticated interior. Perfect for individuals looking for a long-lasting, functional finish with a unique visual appeal.

price available upon request



ALTERNATIVE INSTALLATIONS

We are able to install any product for your van.



Travel without boundaries

At MVan Solutions, we are capable of installing any product for your van.

We provide installation services for swivel bases for front seats, travel-approved sleeper seats, paneling, tanks, air conditioning systems, and painting.

In addition to that, you can discover a diverse selection of accessories including mattresses, tailored seat covers, and multimedia devices featuring CarPlay and Android Auto.



961 €

Thule Omnistor Canopy

214 €

Snorkel Bravo

139 €

Electric stairway



Thule 3200 Omnistor

The Thule Omnistor 3200 is a lightweight and compact manual awning, perfect for direct installation on specific minivans or for mounting on car roof racks.

Created for ease and quickness of use, it can be effortlessly assembled by a single individual.

643,64 €



Thule 4200 Mystic Grey

The optimal wall-mounted awning for campers and caravans features an elegant design that ensures seamless integration with the vehicle, thanks to its newly designed terminal.

Available in lengths ranging from 3.50 to 4.50 m. The tube support enhances fabric tension and minimizes creasing.

961,36 €



Thule Omnistor 6300

The Thule Omnistor 6300 is a roof-mounted awning tailored for campers and vans, perfect for individuals who wish to keep the vehicle's side rail available for alternative uses, including awnings or extra accessories.

It provides a spacious shaded area and efficient protection from both sun and rain.

1121,97 €



Multi-Rail gutter profile

Gutter, awning bracket, and roof rack combined into a single unit with simple attachment using a clamping rod or supply pipes.

The aluminum rail comes pre-drilled and can support roof loads of up to 100 kg.

352,58 €



Thule Quickfit Shelter

Universal and compact veranda awning featuring rapid installation.

Simple and fast setup, no profiles necessary. Durable and lightweight design. Small enough to fit into a compact bag.

1061,17 €



Automatic electric stairway

Fully automatic 900 mm electric step for Crafter I and Sprinter II and III models.

The step surface measures 900 x 160 mm and has a load capacity of 240 kg, making it a unique product.

2251,75 €



80 kg pull-out guides

80kg full extension steel ball bearing drawer slide featuring side-mounted telescopic guides.

The guides feature carbon steel ball bearings and secure when being opened and closed.

643 €



120 kg pull-out guides

120kg full extension steel ball bearing drawer slide featuring side-mounted telescopic guides.

The guides feature carbon steel ball bearings and secure when being opened and closed.

961 €



200 kg pull-out guides

200kg full extension steel ball bearing drawer slide featuring side-mounted telescopic guides.

The guides feature carbon steel ball bearings and secure when being opened and closed.

1121 €



Single cable gland, 6-10 mm

Easy-Fit low-profile, waterproof cable gland for cables measuring 6 to 10 mm, designed to withstand impacts and UV radiation.

Engineered and created to endure environmental factors in the maritime sector.

36,97 €



6-10mm dual cable gland

Easy-Fit watertight double cable gland, designed for cables ranging from 6 to 10 mm, offers resistance to impacts and UV radiation.

Engineered and created to endure environmental factors in the maritime sector.

54,29 €



Third leg support for verandas

Thule Third Support Leg, a crucial accessory for campers seeking secure and hassle-free stops.

Simple to install and compatible with leading Thule awning models, this telescopic bar provides additional support even in breezy conditions.

117,34 €



Msw 48 alloy wheels made of van material

The Msw 48 Van alloy wheels represent the innovative efforts of MSW, a manufacturer known for producing high-quality wheels that cater to the requirements of various vehicles.

These products improve the visual appeal of vehicles and their overall functionality. The incorporation of alloy wheels on vehicles aids in minimizing component wear and enhances driving responsiveness.

commencing
173,53/cad.



Msw 40 alloy wheels in Van design

The Msw 40 Van alloy wheels represent the innovative efforts of MSW, a manufacturer known for producing high-quality wheels that cater to the requirements of various vehicles.

These products improve the visual appeal of vehicles and their overall functionality. The incorporation of alloy wheels on vehicles aids in minimizing component wear and enhances driving responsiveness.

commencing
179,71 €/cad.



Msw 99 Van aluminum wheels

The Msw 99 Van alloy wheels represent the innovative efforts of MSW, a manufacturer known for producing high-quality wheels that meet the requirements of various vehicles.

These products improve the visual appeal of vehicles and their overall functionality. The incorporation of alloy wheels on vehicles aids in minimizing component wear and enhances driving responsiveness.

commencing
223,46 €/cad.



DAB Radio with Apple CarPlay and Android Auto

The LX 7100 Alpine Halo II represents the second generation of Alpine's well-known Halo product line, boasting an impressive 11-inch high-resolution WXGA touchscreen and compatibility with nearly any vehicle equipped with a 1DIN or 2DIN installation dock. This head unit is particularly ideal for vans, pickups, campers, or any vehicle that features a spacious dashboard.

1049,99 €



Wide-angle wireless rearview camera

The camera is equipped with a 1/3 CMOS sensor and a 158° ultra-wide-angle lens. It boasts a waterproof design that guarantees dependable performance in diverse weather conditions.

Transmission range of up to 200 meters guarantees stable and dependable signal transmission.

112,73 €



DAB Radio, Apple CarPlay, and Android

The expert solution for the navigation of heavy vehicles, caravans, or campers.

You will have the ability to utilize your Caravan, Camper, or Truck with designated maps, ensuring you do not need to be concerned about narrow, low, or restricted roads. Compatible with the most recent smartphones

1250€



[@mvansolutions](#)

info@mvan.it

+39 351 396 5126

